

Data Projector

Operating Instructions

VPL-CX76
VPL-CX70

Table of Contents

Overview

About the Supplied Manuals	3
Features	4
Location and Function of Controls	6
Top/Front/Left Side	6
Rear/Right Side/Bottom	6
Control Panel	7
Connector Panel	8
Remote Commander	9
Presentation Tool (VPL-CX76 only)	11

Projecting the Picture

Installing the Projector	12
Connecting the Projector	13
Connecting a Computer	13
Connecting a VCR	14
Projecting	15
Turning Off the Power	18

Convenient Functions

Selecting the Menu Language	19
Security Lock	20
Other Functions	22
Controlling the Computer Using the Supplied Remote Commander (When Using the USB Cable)	22
Controlling the Computer Using the Supplied Presentation Tool (When Using the Air Shot) (VPL-CX76 only)	22
Off & Go Function	22
Effective Tools for Your Presentation	23

Adjustments and Settings Using a Menu

Using a MENU	24
The PICTURE SETTING Menu	26
The INPUT SETTING Menu	27
About the Preset Memory No.	28
The SET SETTING Menu	29
The MENU SETTING Menu	31
The INSTALL SETTING Menu	32
The INFORMATION Menu	34

Maintenance

Replacing the Lamp	36
Cleaning the Air Filter	38

Others

Troubleshooting	39
Messages List	42
Specifications	44
“Side Shot” and “V Keystone” Adjustments	49
Dimensions	51
Index	52

About the Supplied Manuals

The following manuals and softwares are supplied with this unit.

For the VPL-CX70, read the Safety Regulations, Quick Reference Manual, and Operating Instructions (for the VPL-CX76/VPL-CX70). Other manuals on the CD-ROM and other software applications were not prepared for the VPL-CX70. Also, the Operating Instructions for the VPL-CX86/VPL-CX80 are included on the CD-ROM, but are not used for this unit. On Macintosh system, you can read only the Operating Instructions for the VPL-CX76/VPL-CX70.

Manuals

Safety Regulations (separately printed manual)

This manual describes important notes and cautions to which you have to pay attention when handling and using this product.

Quick Reference Manual (separately printed manual)

This manual describes basic operations for projecting pictures after you have made the required connections.

Operating Instructions (for the VPL-CX76/VPL-CX70) (on the CD-ROM) (this manual)

This Operating Instructions describes the setup and operations of this unit. Model VPL-CX76 is used for illustration purposes throughout this manual. Any differences in operation are indicated in the text, for example, “VPL-CX76 only.”

Operating Instructions (for the VPL-CX86/VPL-CX80) (on the CD-ROM)

This Operating Instructions has been prepared for the VPL-CX86/VPL-CX80. This instruction is not used for this unit.

Operating Instructions for “Memory Stick” (on the CD-ROM) (VPL-CX76 only)

This Operating Instructions describes how to view slides using files sorted in a “Memory Stick”.

Operating Instructions for Air Shot (on the CD-ROM) (VPL-CX76 only)

This Operating Instructions describes how to set up and operate the Air Shot.

User’s Guide for the USB Wireless LAN Module Utility (on the CD-ROM) (VPL-CX76 only) (Japanese and English only)

This Operating Instructions describes how to set up the USB Wireless LAN module.

Note

You must have Adobe Acrobat Reader 5.0 or higher is installed to read the Operating Instructions stored on the CD-ROM.

Software (on the CD-ROM)

Projector Station for Air Shot Version 2 (VPL-CX76 only) (Japanese and English only)

This is an application software for transmitting data from a computer to the projector via wireless LAN.

Projector Station for Presentation (VPL-CX76 only) (Japanese and English only)

This is an application software for creating the files for a presentation performed using the “Memory Stick”.

USB Wireless LAN Module Utility (VPL-CX76 only) (English only)

This is a software for setting the USB wireless LAN module. (When the projector is used in simple mode, it is not necessary to install this software.)

Features

High brightness, high picture quality

High brightness

Adopting Sony's unique optical system that incorporates provides a high-efficiency optical system. It allows the 165 W UHP lamp to give a light output of 2500 ANSI lumen (VPL-CX76), 2000 ANSI lumen (VPL-CX70).

High picture quality

Three super-high-aperture 0.79-inch XGA panels with approximately 790,000 effective pixels, produce a resolution of 1024 × 768 dots (horizontal/vertical) for RGB input, and 750 horizontal TV lines for video input.

Variety of network presentations (VPL-CX76 only)

Air Shot

Air Shot features data transmission from a computer to the projector via a wireless LAN.

Use of the supplied wireless LAN card (for the projector) and the USB wireless LAN module (for a computer) enables a wireless presentation.

A Simple Mode is also available that does not require the setting up of the network and wireless LAN configurations, allowing you to start a wireless presentation easily if you are using the wireless LAN for the first time.

For more information, refer to “Operating Instructions for Air Shot” and “Projector Station for Air Shot Version 2 Help” on the supplied CD-ROM.

Presentation without connecting a computer

Use of a “Memory Stick” enables you to run a simple presentation without connecting a computer.

The “Projector Station for Presentation” software is supplied, with the projector allowing you to create files for a presentation.

For more information, refer to “Operating Instructions for “Memory Stick”” and “Projector Station for Presentation” in Help.

Presentation tool with a laser pointer

The supplied presentation tool allows you to use a laser pointer, or to change a slide to the next or previous page during your Air Shot presentation.

Quiet presentation environment

Low fan noise reduces distraction allowing you to run an optimum presentation even in a quiet environment.

Easy setup and simple operation

Advanced Intelligent Auto-setup function with auto focus adjustment

Simply press the power key, and the projector automatically performs the setups required before use. The projector opens the lens protector, corrects the V Keystone, adjusts the focus automatically, detects a signal, and sets optimum conditions for projection.

Powered zoom/focus equipped

The projector is equipped with a powered zoom and powered focus lens, allowing you to adjust the size and focus of an image with the Remote Commander away from the projector.

Short focal lens

The projection distance is very short, approximately 2.4 m (7.8 feet), when projecting an 80-inch image, which allows projection on a larger screen even in a limited space.

Side Shot

The projector supports the Side Shot feature (horizontal trapezoidal correction function), enabling projection from the side of the screen. Installation becomes possible in a wider variety of locations.

Off & Go feature

The cooling fan built into the projector will work even after the power is turned off and the power cord is disconnected. This enables you to move the projector to another location immediately after turning it off.

System expandability using a network (VPL-CX76 only)

Connection to a wireless LAN allows you to obtain projector status information such as the lamp timer status or to control the projector away from the installation location via a Web browser.

Also, the projector has a mail report function to send the information on the time to replace the lamp and error information to the address set beforehand and corresponds to SNMP.

Security Functions

Security lock

This function makes it possible to prevent projection of a picture on the screen unless the required password is entered when the projector is turned on.

Panel key lock

This function locks all the keys on the control panel of the projector, allowing use of the keys on the Remote Commander. This prevents the projector from operating incorrectly.

About Trademarks

- Adobe Acrobat is a trademark of Adobe Systems Incorporated.
- Windows is a registered trademark of Microsoft Corporation in the United States and/or other countries.
- VGA, SVGA, XGA and SXGA are registered trademarks of the International Business Machines Corporation, U.S.A.
- Kensington is a registered trademark of Kensington Technology Group.
- Macintosh is a registered trademark of Apple Computer, Inc.
- VESA is a registered trademark of the Video Electronics Standard Association.

- Display Data Channel is a trademark of the Video Electronics Standard Association.
- “Memory Stick” and  are trademarks of Sony Corporation.
- Air Shot is a trademark of Sony Corporation.
- Side Shot is a trademark of Sony Corporation.

Location and Function of Controls

Top/Front/Left Side

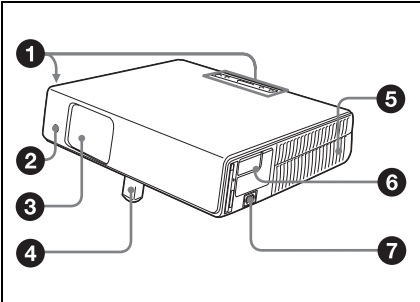

Rear/Right Side/Bottom

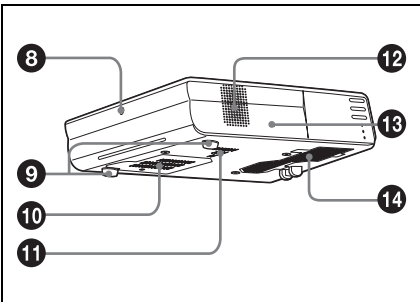

1 Control panel

For details, see “Control Panel” on page 7.

2 Front remote control detector

3 Lens protector (lens cover)

The lens protector opens automatically when the power is turned on.

4 Powered tilt adjuster

5 Ventilation holes (exhaust)

6 Connector Panel

For details, see “Connector Panel” on page 8.

7 AC IN socket

Connects the supplied AC power cord.

8 Rear remote control detector

9 Adjusters (hind pad)

Turn the appropriate adjuster to the right or left for minor tilt adjustment of the projected picture.

10 Ventilation holes (intake)/Lamp cover

11 Ventilation holes (intake)

12 Speaker

13 Security lock

Connects to an optional security cable (from Kensington).

Web page address:

<http://www.kensington.com/>

14 Ventilation holes (intake)/Air filter cover

Notes

- Do not place anything near the ventilation holes as this may cause internal heat build-up.
- Do not place your hand near the ventilation holes as this may cause injury.
- To maintain optimal performance, **clean the air filter every 500 hours.**

For details, see “Cleaning the Air Filter” on page 38.

Control Panel

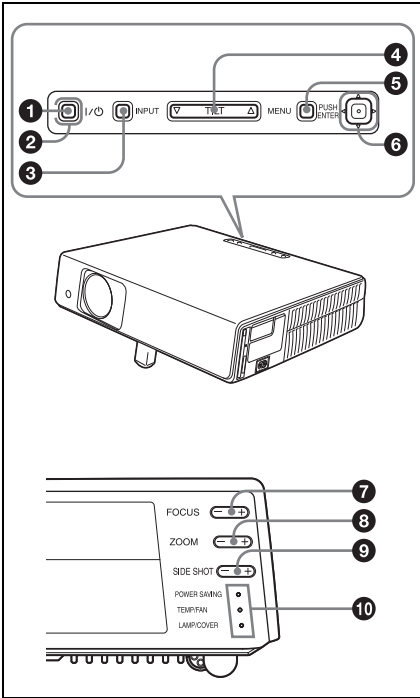

1 I/⏻ (On/Standby) key

Turns on the projector when the projector is in standby mode. The ON/STANDBY indicator around the I/⏻ key flashes in green until the projector is ready to operate.

2 ON/STANDBY indicator (located around the I/⏻ key)

Lights up or flashes under the following conditions:

- Lights in red when the AC power cord is plugged into a wall outlet. Once the projector is in standby mode, you can turn it on with the I/⏻ key.
- Lights in green when the power is turned on, and when it is ready to operate.
- Flashes in green from the projector is turned on until the projector is ready to operate. Also, flashes in green while the cooling fan is running after the power is turned off with the I/⏻ key.

The fan runs for about 90 seconds after the power is turned off.

For details, see page 18.

3 INPUT key

4 TILT adjustment key

For details, see “Projecting” on page 15.

5 MENU key

Displays the on-screen menu. Press again to clear the menu.

6 ENTER/Δ/∇/◀/▶ (Arrow) keys

Used to enter the settings of items in the menu system, select a menu, or make various adjustments.

7 FOCUS +/- keys

Adjusts the picture focus.

8 ZOOM +/- keys

Adjusts the picture size.

9 SIDE SHOT +/- key

Adjusts the horizontal trapezoidal distortion/H keystone correction of the picture.

For details, see “Even when projecting using “Side Shot”, the four sides of a picture may sometimes not be parallel to the respective sides of a screen frame.” on page 33 and ““Side Shot” and “V Keystone” Adjustments” on page 49.

10 Status indicators

• POWER SAVING

Lights when the projector is in power saving mode.

• TEMP (Temperature)/FAN

Lights or flashes under the following conditions:

- Lights when the temperature inside the projector becomes unusually high.
- Flashes when the fan is broken.

• LAMP/COVER

Lights or flashes under the following conditions:

- Lights when the lamp has reached the end of its life or reaches a high temperature.

- Flashes when the lamp cover or air filter cover is not secured firmly.

For details, see page 42.

Connector Panel

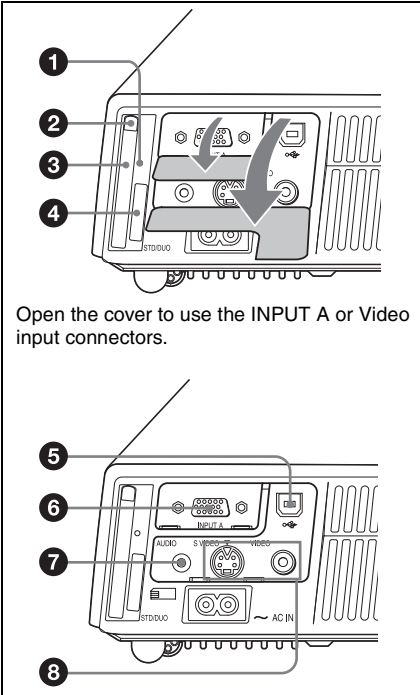

Open the cover to use the INPUT A or Video input connectors.

1 Access lamp (VPL-CX76 only)

Lights during access to the “Memory Stick”.

Do not remove the “Memory Stick” while the access lamp is lit.

2 Wireless LAN card eject button (VPL-CX76 only)

3 Wireless LAN card slot (VPL-CX76 only)

The supplied wireless LAN card can be inserted. Never insert anything other than the supplied wireless LAN card.

Note

Remove the wireless LAN card from the wireless LAN card slot when storing the projector in the carrying case.

For details, see *Operating Instructions for Air Shot* (stored on the CD-ROM).

4 Memory Stick slot (for standard/ Duo size) (VPL-CX76 only)

A “Memory Stick” can be inserted here. Never insert an object other than the “Memory Stick” into this slot.

Note

(The standard “Memory Stick”/ “Memory Stick Duo” compatible slot)

You can use both of the standard size “Memory Stick” and the “Memory Stick Duo” in the same slot. (You cannot use both sizes of “Memory Stick” at the same time.) When you use a “Memory Stick Duo”, do not attach the Memory Stick Duo Adaptor to it.

Do not insert more than one “Memory Stick” into the slot at the same time or insert the “Memory Stick” in the opposite direction. This will cause a malfunction of this unit.

For details, see the attached “*Operating Instructions for “Memory Stick”*” stored on the CD-ROM.

5 USB connector (USB plug for upstream, 4-pin)

Connects to the USB connector of a computer. When you connect the projector to the computer, you can control the mouse function with the supplied Remote Commander.

6 INPUT A connector (HD D-sub 15-pin, female)

Inputs a computer signal, video GBR signal, component signal, or DTV signal depending on the connected equipment. Connects to the output connector of equipment using the supplied cable or an optional cable.

For details, see “*Connecting a Computer*” on page 13 and “*Connecting a VCR*” on page 14.

7 AUDIO jack (stereo minijack)

To listen to sound output from video equipment or a computer, connect via

this jack to the audio output of the video equipment or the computer.

8 Video input connector

Connects to external video equipment such as a VCR.

- **S VIDEO (mini DIN 4-pin):** Connects to the S video output (Y/C video output) of video equipment.
- **VIDEO (phono type):** Connects to the composite video output of video equipment.

Remote Commander

The keys that have the same names as those on the control panel function identically.

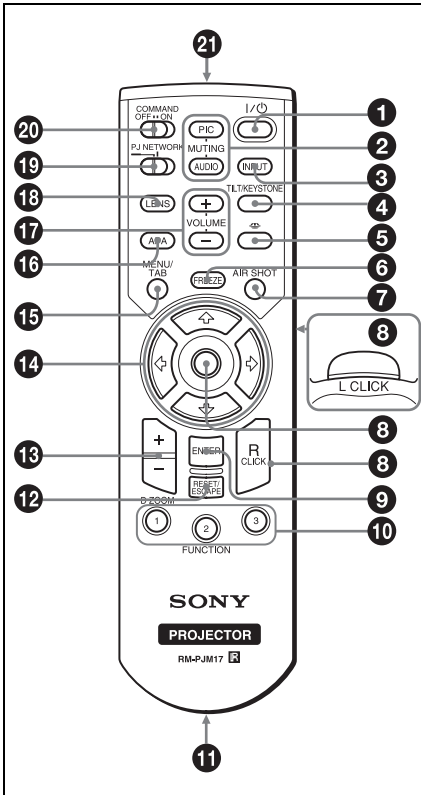

1 I/O (On/Standby) key

2 MUTING keys

Cut off the picture and sound.

- **PIC:** Cuts off the picture. Press again to restore the picture.
- **AUDIO:** Press to temporarily cut off the audio output from the speaker. Press again, or press the VOLUME + key to restore the sound.

3 INPUT key

4 TILT/KEystone (Vertical/horizontal trapezoidal distortion correction) key

Adjusts the tilt of the projector, or the horizontal/vertical trapezoidal distortion of the image manually. Each time you press this key, the Tilt menu, the V Keystone menus, and the Side Shot menu are displayed in turn. Use the arrow keys (↑/↓/←/→) for adjustment.

5 Memory Stick (VPL-CX76 only)

Displays the “Memory Stick” Home. When the input signal is other than from a “Memory Stick”, it switches to “Memory Stick”. When there are the files to be displayed in the “Memory Stick” Home, the slide show begins.

For details, see “Operating Instructions for “Memory Stick”” (stored on the CD-ROM).

6 FREEZE key

Freezes the projected picture. To cancel the frozen picture, press the key again.

7 AIR SHOT key (VPL-CX76 only)

Displays the Air Shot Home. When the input signal is other than from Air Shot, it switches to Air Shot. When using the Air Shot, the list box of computers that can be connected appears.

For details, see “Operating Instructions for Air Shot” (stored on the CD-ROM).

8 Mouse-emulation keys

These keys function as the mouse buttons of a computer only when the projector is connected to a computer using the USB cable.

For details, see “Controlling the Computer Using the Supplied Remote Commander (When Using the USB Cable)” on page 22.

9 ENTER key

10 FUNCTION 1, 2, 3 keys

The FUNCTION 1 and 2 keys do not work on this unit.

The auto focus function works when the FUNCTION 3 key is pressed.

11 Strap holder

For attaching a strap.

12 RESET/ESCAPE key

Functions as a RESET key.

Resets the value of an item to its factory preset value or returns the enlarged image to its original size. This key functions when the menu or a setting item is displayed on the screen.

13 D ZOOM (Digital Zoom) +/- key

Enlarges the image at a desired location on the screen.

14 ↑/↓/←/→ keys (Arrow)

15 MENU/TAB key

Functions as a MENU key.

16 APA (Auto Pixel Alignment) key

Automatically adjusts a picture to its clearest while a signal is input from a computer.

For details, see “Smart APA” in “The SET SETTING Menu” on page 29.

17 VOLUME +/- keys

18 LENS key

Each time you press this key, the Focus adjustment and Zoom adjustment menus are displayed alternately.

19 PJ NETWORK (Projector/ Network) selector switch

Normally, set to “PJ.”

20 COMMAND ON/OFF switch

When this switch is set to OFF, the keys on the Remote Commander do not function. This saves battery power.

21 Infrared transmitter

To install batteries

- 1 Push and slide the lid to open it, then install the two size AA (R6) batteries (supplied) with the correct polarity.

While pressing the lid, slide it.

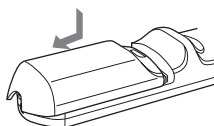

Be sure to install the battery from the ⊖ side.

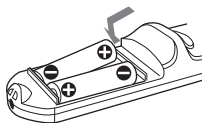

- 2 Replace the lid.

Presentation Tool (VPL-CX76 only)

You can use a laser pointer or control a presentation file made using Microsoft PowerPoint when projecting a picture using the Air Shot feature.

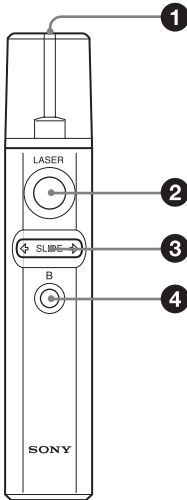

1 Laser transmitter

2 LASER key

A laser beam is emitted from the laser transmitter while you keep this key pressed.

3 SLIDE </> key

Used to change pages of the slide show in the forward/backward direction.

4 B key

This key corresponds to the “B” key of a keyboard.

When you press this key during the slide show, a black screen is displayed. To cancel the black screen, press this key again.

Note

A black screen may not be displayed even if you press the “B” key depending on the

language of the operating system (OS) of your computer.

To install the batteries

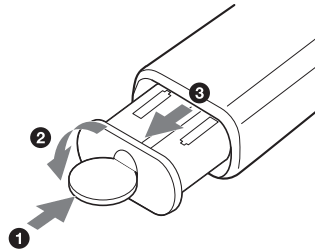

Open the cover (2) with a coin (1) and remove the battery case (3). Install the two size AAA (R03) batteries with the correct polarity.

Notes on the laser beam

- Do not look into the laser transmitter.
- Do not aim the laser at people.

Notes on Remote Commander/ Presentation tool operation

- Make sure that nothing obstructs the infrared beam between the Remote Commander/Presentation tool and the remote control detector on the projector. Direct the Remote Commander/Presentation tool toward the front or rear remote control detector.
- The operation range is limited. The shorter the distance between the Remote Commander/Presentation tool and the projector is, the wider the angle within which the commander can control the projector becomes.

Installing the Projector

The distance between the lens and the screen varies depending on the size of the screen. Use the following table as a guide.

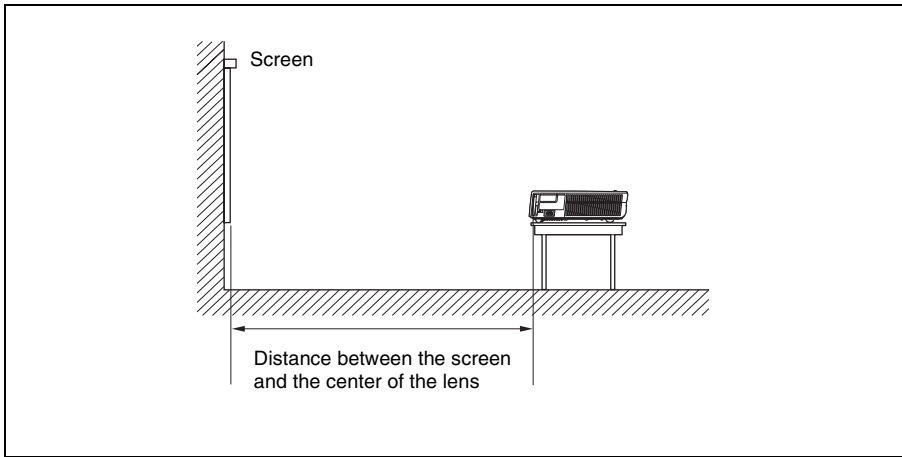

Unit: m (feet)

Screen size (inches)	40	80	100	150	200	250	300
Minimum Distance	1.2 (3.9)	2.4 (7.9)	3.0 (9.8)	4.5 (14.8)	6.0 (19.7)	7.5 (24.6)	9.0 (29.5)
Maximum Distance	1.4 (4.6)	2.7 (8.9)	3.4 (11.2)	5.2 (17.1)	6.9 (22.6)	8.7 (28.5)	10.4 (34.1)

There may be a slight difference between the actual value and the design value shown in the table above.

Connecting the Projector

When you connect the projector, make sure to:

- Turn off all equipment before making any connections.
- Use the proper cables for each connection.
- Insert the cable plugs firmly; loose connections may increase noise and reduce performance of picture signals. When pulling out a cable, be sure to pull it out by the plug, not the cable itself

When connecting to a wireless LAN using the Air Shot, see “Operating Instructions for Air Shot” stored on the CD-ROM (VPL-CX76 only).

Connecting a Computer

This section describes how to connect the projector to a computer. For more information, refer to the computer’s instruction manual.

To connect a computer

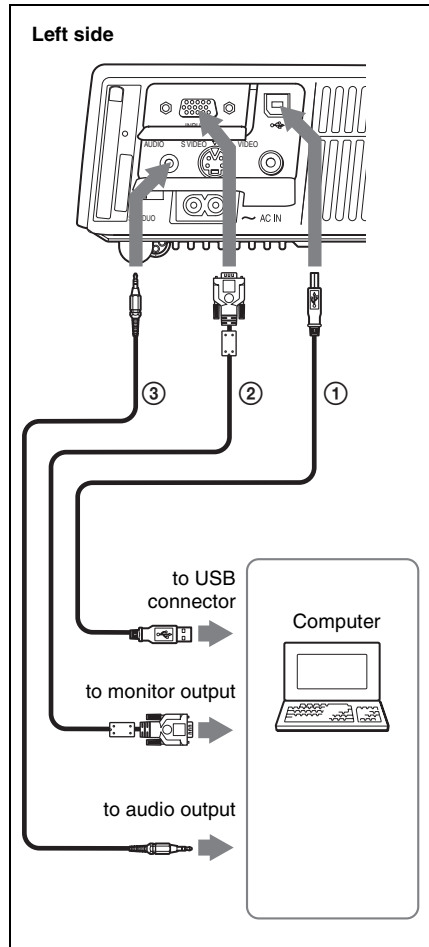

- ① USB cable (supplied)(Connect the USB cable to use a wireless mouse.)
- ② HD D-sub 15-pin cable (supplied)
- ③ Stereo audio connecting cable (not supplied) (Use a no-resistance cable.)

Notes

- The projector accepts VGA, SVGA, XGA, SXGA, and SXGA+ signals. However, we recommend that you set the output mode of your computer to XGA mode for the external monitor.
- If you set your computer, such as a notebook computer, to output the signal to both your computer’s display and the external monitor, the picture of the external monitor may not

appear properly. Set your computer to output the signal to only the external monitor.

For details, refer to the operating instructions supplied with your computer.

Note

To connect a Macintosh computer equipped with a video output connector of a type having two rows of pins, use a commercially available plug adaptor.

USB function

When connecting the projector to a computer using the USB cable for the first time, the computer recognizes the USB human interface device (wireless mouse function) automatically.

Recommended operating environment

When you use the USB function, connect the USB cable as illustrated. The USB function can be used on a computer loaded with Windows 98, Windows 98 SE, Windows ME, Windows 2000, or Windows XP (preinstalled models.)

Notes

- Your computer may not start correctly when connected to the projector via the USB cable. In this case, disconnect the USB cable, restart the computer, then connect the computer to the projector using the USB cable.
- This projector is not guaranteed for suspend or standby mode. When you use the projector in suspend, or standby mode, disconnect the projector from the USB port on the computer.
- Operations are not guaranteed for all the recommended computer environments.
- When you connect a USB-capable Macintosh computer to the projector using the USB cable, wireless mouse functions become available.
- A “Memory Stick” inserted into the Memory Stick slot on the projector cannot be accessed from the Projector Station for Presentation (VPL-CX76 only).

Connecting a VCR

This section describes how to connect the projector to a VCR.

For more information, refer to the instruction manuals of the equipment you are connecting.

To connect to a video or S video output connector

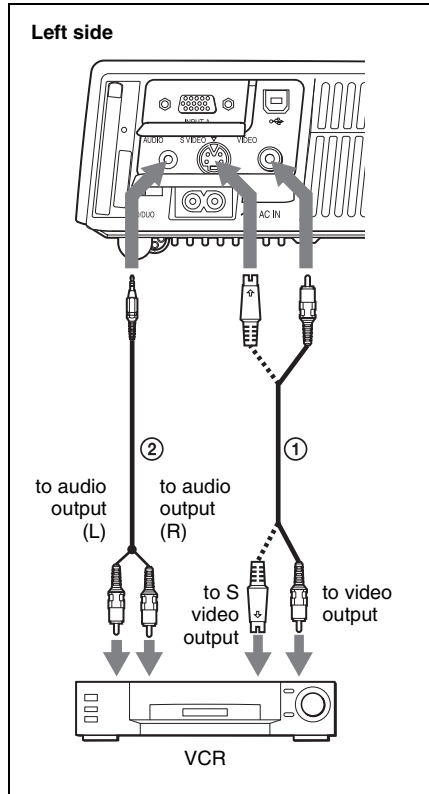

- ① Video cable (not supplied) or S-Video cable (not supplied)
- ② Stereo audio connecting cable (not supplied)
(Use a no-resistance cable.)

**To connect to a video GBR/
Component output connector**

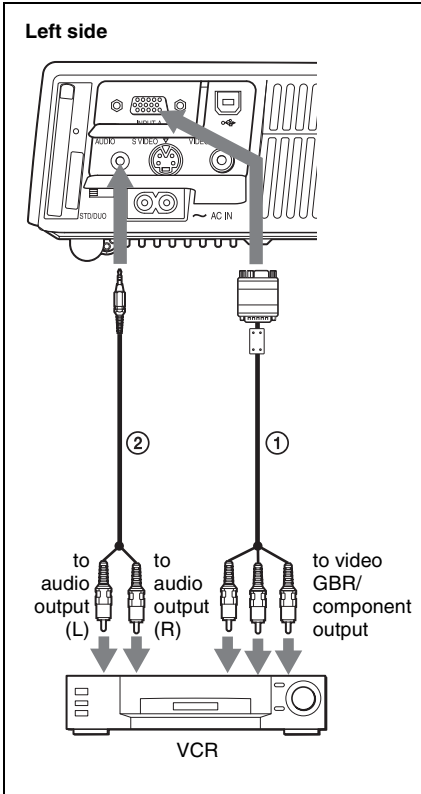

- ① SMF-402 Signal Cable (not supplied)
HD D-sub 15-pin (male) ↔ 3 × phono jack
- ② Stereo audio connecting cable (not supplied)
(Use a no-resistance cable.)

Notes

- Set the aspect ratio using “Wide Mode” on the INPUT SETTING menu according to the input signal.
- When you connect the projector to a video GBR output connector, select “Video GBR” or when you connect the projector to a component output connector, select “Component” with the “Input-A Signal Sel.” setting on the SET SETTING menu.
- Use the composite sync signal when you input the external sync signal from video GBR/component equipment.

Projecting

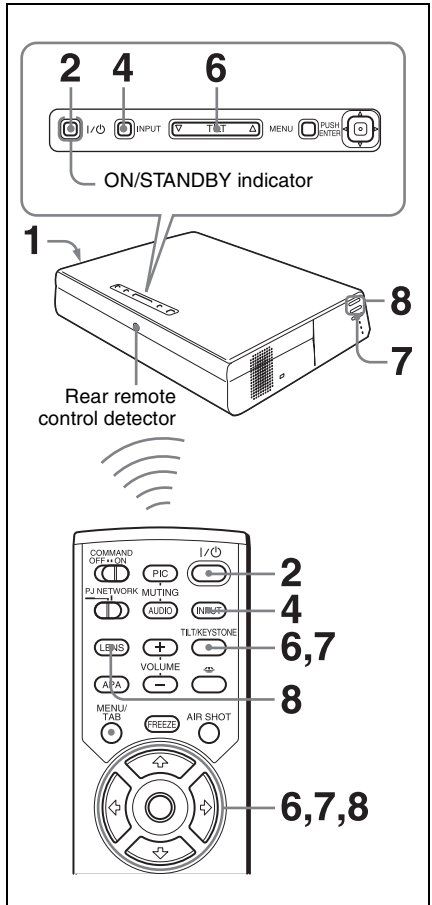

- 1** Plug the AC power cord into a wall outlet, then connect all equipment. The ON/STANDBY indicator lights in red and the projector goes into standby mode.
- 2** Press the I/O key. The ON/STANDBY indicator flashes in green and the Advanced Intelligent Auto-setup starts. The lens protector opens, the powered tilt adjuster rises and stops at the previously adjusted position and adjusts the focus.

Projecting the Picture

Notes

- The projection size that can be adjusted with the automatic focus adjustment is from 40-inch up to 150-inch. However, it may not be perfectly adjusted depending on the brightness of the room, the state of the screen, or the use of the Side Shot. In this case, adjust it manually in step **8** on page 17.
- When the projector is turned on, the Startup screen is projected (VPL-CX76 only).

For details, see the attached “Operating Instructions for “Memory Stick”” stored on the CD-ROM.

- 3** Turn on the equipment connected to the projector.
- 4** Press the INPUT key to select the input source.

Each time you press the key, the input signal switches as follows:

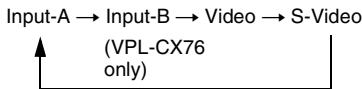

To input from	Press INPUT to display
Computer connected to the INPUT A connector	Input-A
Air Shot/“Memory Stick” (when you use the Air Shot/“Memory Stick”) (VPL-CX76 only)	Input-B
Video equipment connected to the VIDEO input connector	Video
Video equipment connected to the S VIDEO input connector	S-Video

Smart APA (Auto Pixel Alignment) adjusts the picture of the connected equipment so that it is projected clearly.



Notes

- For Input-B, input from the “Air Shot” or “Memory Stick” can be switched by selecting with the Input-B Select menu, or pressing the  key or the AIR SHOT key on the Remote Commander. The Air Shot Home or the Memory Stick Home is displayed on the screen (VPL-CX76 only).
- If “Auto Input Search” is set to “On,” the projector searches for the signals from the connected equipment and displays the input channel where the input signals are found.

For details, see “Auto Input Search” on page 29.

- The Smart APA feature is effective for the input signal from a computer only.

- 5** Switch the equipment connected to output to the projector.

Depending on the type of your computer, for example a notebook, or an all-in-one LCD type, you may have to switch the computer to output to the projector by pressing certain keys (e.g., , , , etc.), or by changing your computer’s settings.

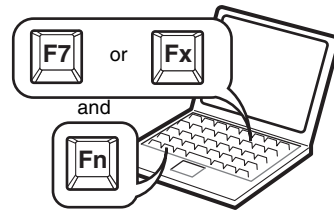

Note

The key used for switching the computer to output to the projector varies depending on the type of computer.

- 6** Adjust the upper or lower position of the picture.

To adjust using the Remote Commander

Press the TILT/KEystone key on the Remote Commander to display the Tilt

menu and adjust the tilt using the $\uparrow/\downarrow/\leftarrow/\rightarrow$ keys.

To adjust using the control panel

Press Δ or ∇ of the TILT key to adjust the tilt of the projector.

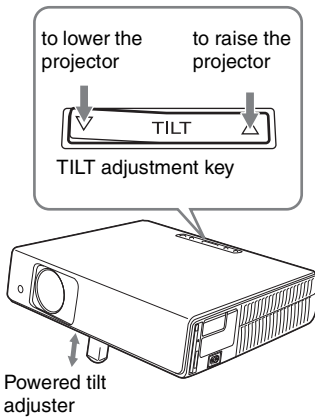

Notes

- When you adjust the powered tilt adjuster with the TILT key, the V keystone adjustment is performed at the same time. If you do not want to perform the automatic keystone adjustment, set the V Keystone menu to “Manual.” (See page 32.)
If you set the “V Keystone” adjustment to “Auto,” the “V Keystone” correction is automatically adjusted. However, it may not be perfectly adjusted depending on the room temperature or the screen angle. In this case, adjust it manually. Press the TILT/KEYSTONE key on the Remote Commander until “V Keystone” appears on the screen, and adjust the value with the $\uparrow/\downarrow/\leftarrow/\rightarrow$ keys. The corrected value is effective until the power is turned off.
- Be careful not to let the projector down on your fingers.
- Do not push hard on the top of the projector with the powered tilt adjuster extended.
It may cause a malfunction.

7 Adjust the horizontal trapezoidal distortion () of the picture using the “Side Shot.”

To adjust using the Remote Commander

Press the TILT/KEYSTONE key on the Remote Commander to display the Side Shot menu (horizontal trapezoidal distortion/H keystone correction) and adjust the tilt using the $\uparrow/\downarrow/\leftarrow/\rightarrow$ keys.

To adjust using the control panel

Press the SIDE SHOT +/- key on the control panel to adjust the distortion.

For details, see “Side Shot” on page 32 and “Side Shot” and “V Keystone Adjustments” on page 49.

8 Adjust the size of the picture and the focus.

To adjust using the Remote Commander

Select the item to be adjusted by pressing the LENS key, then adjust with the $\uparrow/\downarrow/\leftarrow/\rightarrow$ key. Each time you press the key, the menu toggles between Lens Focus and Lens Zoom in order.

To adjust using the control panel

Press the ZOOM +/- keys on the projector to adjust the size of the picture and press the FOCUS +/- keys to adjust the focus.

Turning Off the Power

- 1 Press the I/⏻ key.
“POWER OFF? Please press I/⏻ key again.” appears to confirm that you want to turn off the power.

Note

The message disappears if you press any key other than the I/⏻ key, or if you do not press any key for five seconds.

- 2 Press the I/⏻ key again.
The lens protector closes and the powered tilt adjuster is retracted into the projector. The ON/STANDBY indicator flashes in green and the fan continues to run to reduce the internal heat. Also, the ON/STANDBY indicator flashes quickly for the first 45 seconds. During this time, you will not be able to light up the ON/STANDBY indicator again with the I/⏻ key.
- 3 Unplug the AC power cord from the wall outlet after the fan stops running and the ON/STANDBY indicator lights in red.

When you cannot confirm the on-screen message

When you cannot confirm the on-screen message under certain conditions, you can turn off the power by holding the I/⏻ key for about two seconds instead of following steps 1 and 2.

Note

The internal circuitry of the Off & Go function may cause the fan to continue to operate for a short time even after the I/⏻ key is pressed to turn off the power and the ON/STANDBY indicator changes to red.

► **Convenient Functions**

Selecting the Menu Language

You can select one of fifteen languages for displaying the menu and other on-screen displays. The factory setting is English. To change the menu language, proceed as follows:

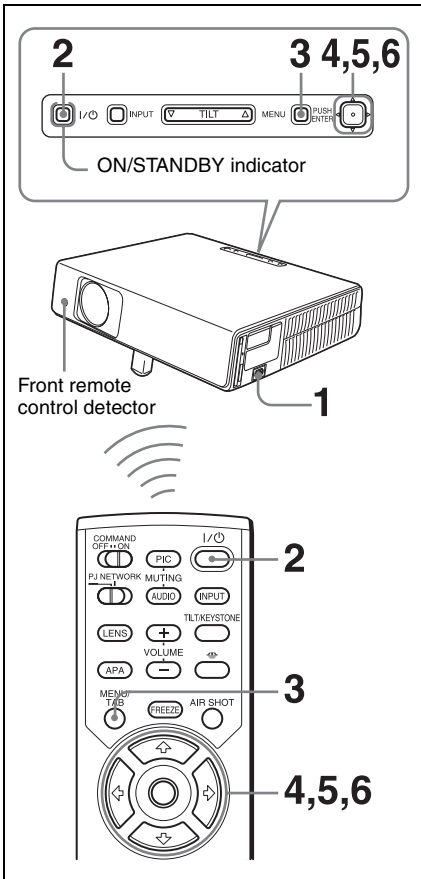

- 1 Plug the AC power cord into a wall outlet.
- 2 Press the I/⏻ key to turn on the projector.

- 3 Press the MENU key.
The menu appears.
The menu currently selected is shown as a yellow button.

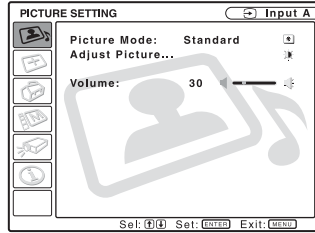

- 4 Press the ↑ or ↓ key to select the MENU SETTING menu, then press the → or ENTER key.
The selected menu appears.

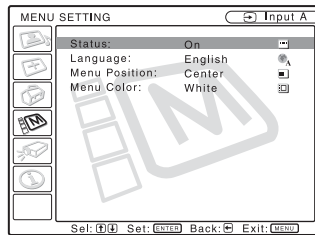

- 5 Press the ↑ or ↓ key to select "Language," then press the → or ENTER key.

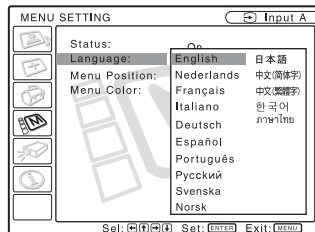

- 6 Press the ↑, ↓, ← or → key to select a language, then press the ENTER key.
The menu changes to the selected language.

To clear the menu

Press the MENU key.

The menu disappears automatically if a key is not pressed for one minute.

Security Lock

The projector is equipped with a security lock function. When you turn the power of the projector on, you are required to input the previously set password. If you do not input the correct password, you will not be able to project the picture.

Note

You will not be able to use the projector if you forget your password and the password administrator is not available. Be please aware that using the security lock can prevent valid usage in such cases.

To use the security lock

1 Press the MENU key and then, on the INSTALL SETTING menu, turn on the “Security Lock” setting.

2 Enter the password.

Use the MENU, ←/→/↑/↓, and ENTER keys to enter the four-digit password. (The default initial password setting is “ENTER, ENTER, ENTER, ENTER.” After this is entered you can put in your own password. Therefore, when you use this function for the first time, please input “ENTER” four times.)

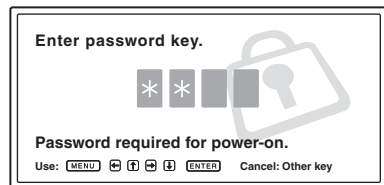

Next, the screen for entering the new password is displayed. (Enter the password on this screen even if you want to keep the current password.)

Enter the password on this screen.

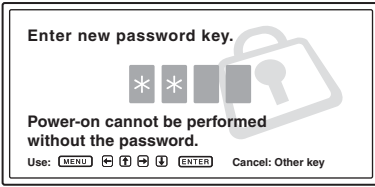

3 Enter the password again to confirm.



When the following message is displayed, the setting for security lock is completed.

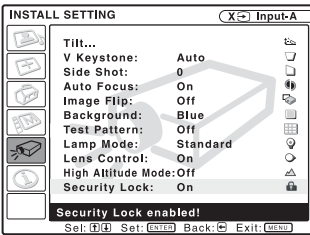

If “Invalid Password!” is displayed on the menu screen, perform this procedure again from step 1.

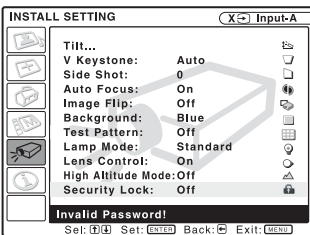

4 Turn the main power off and disconnect the AC power cord.

The security lock is set to on, then it becomes effective. The screen used for entering the password is displayed when the power is turned on the next time.

Security certification

When the password screen is displayed, enter the password that was set. If you fail to enter the correct password after three tries, the projector cannot be used. In this case, press the I/O key to turn off the power.

To cancel the security lock

1 Press the MENU key, then turn off the “Security Lock” setting on the INSTALL SETTING menu.

2 Enter the password.
Enter the password that was set.

Note

If you call the customer service center because you have forgotten the password, you will need to be able to verify the projector’s serial number and your identity. (This process may differ in other countries/regions.) Once your identity has been confirmed, we will provide you with the password.

Other Functions

Controlling the Computer Using the Supplied Remote Commander (When Using the USB Cable)

When you connect a computer to the projector using the USB cable, you can control the mouse of the computer using the Remote Commander.

The R/L CLICK keys and joystick function as follows.

Key and joystick	Function
R CLICK (front)	Right button
L CLICK (rear)	Left button
Joystick	Corresponds to the movements of the mouse

For details, see “To connect a computer” on page 13.

Note

Make sure that nothing obstructs the infrared beam between the Remote Commander and the remote control detector on the projector.

Controlling the Computer Using the Supplied Presentation Tool (When Using the Air Shot) (VPL-CX76 only)

When you are using the Air Shot to project the picture from a computer, you can perform some operations for a slide show using the supplied presentation tool. The following keys on the presentation tool are usable.

Key	Function
LASER	Emits a laser beam.*
⇄ SLIDE ⇄	Changes the slides in the forward/backward direction.

Key	Function
B	Displays/cancels a black screen during the slide show.

* Also available when you are not using the Air Shot.

Notes

- If there is any obstruction between the presentation tool and the remote control detector on the projector, the presentation tool may not function properly.
- A black screen may not be displayed even if you press the “B” key depending on the operating system (OS) of the language of your computer.

Off & Go Function

If you are leaving the conference room immediately, turn the projector off, and then, after the lens protector closes and the powered tilt adjuster is retracted into the projector, you can unplug the AC power cord. After the AC power cord is unplugged, the fan runs for a certain time automatically.

Notes

- When unplugging the AC power cord, ensure that the lens protector has closed and the powered tilt adjuster has been retracted into the projector. Moving the projector with the powered tilt adjuster extended may damage the adjuster.
- Turn off the projector according to the procedure explained in “Turning Off the Power,” then cool it down before storing the projector in the carrying case.
- However, if the unit has been on for less than 15 minutes, the fan might not begin to turn as a result of inadequate charging. In that case, follow the procedure for turning off the power as described in “Turning Off the Power” on page 18.

Effective Tools for Your Presentation

To enlarge the image (Digital Zoom function)

You can select a section of the image to enlarge. This function works when a signal from a computer is input, or when a still picture (except a movie picture) stored in a "Memory Stick" is projected. This function does not work when a video signal is input.

- 1 Project a normal image, and press the D ZOOM + key on the Remote Commander.

The digital zoom icon appears in the center of the image.

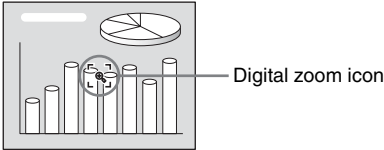

- 2 Move the icon to the point on the image you want to enlarge. Use the arrow key (↑/↓/←/→) to move the icon.

- 3 Press the D ZOOM + key again.
The portion of the image where the icon is located is enlarged. The enlargement ratio is displayed on the screen for a few seconds.
By pressing the + key repeatedly, the image size (ratio of enlargement: max. 4 times) increases.

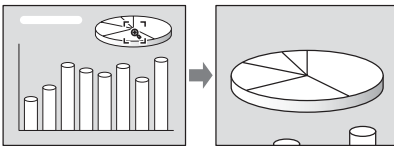

Use the arrow key (↑/↓/←/→) to scroll the enlarged image.

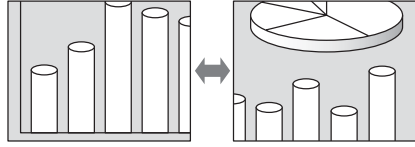

To return the image to its original size

Press the D ZOOM - key.
Just pressing the RESET key returns the image back to its original size immediately.

To freeze the image projected (Freeze function)

Press the FREEZE key. "Freeze" appears when the key is pressed. This function works when a signal from a computer is input or when a still picture stored in a "Memory Stick" is projected.
To restore the original screen, press the FREEZE key again.

Using a MENU

The projector is equipped with an on-screen menu for making various adjustments and settings.

Display items

Input signal indicator



Input signal setting indicator

Picture adjustment menu

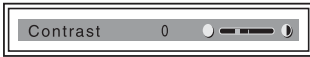

Input signal indicator

Shows the selected input channel.  is displayed when no signal is input. You can hide this indicator using “Status” on the MENU SETTING menu.

Input signal setting indicator

For Input-A: Shows “Computer,”

“Component,” or “Video GBR.”

For Input-B: Shows “Air Shot” or

“Memory Stick” (VPL-CX76 only)



For Video/S-Video input: Shows “Auto” or the “Color System” setting on the SET SETTING menu.

1 Press the MENU key.

The menu appears.

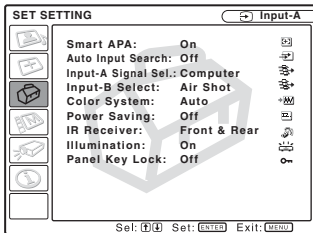

The menu presently selected is shown as a yellow button in the column on the left.



2 Use the  or  key to select a menu, then press the  or ENTER key.

The selected menu appears.

3 Select an item.

Use the  or  key to select the item, then press the  or ENTER key.

The setting items are displayed in a pop-up menu or in a sub menu.

Pop-up menu

Menu Setting items Selected input signal

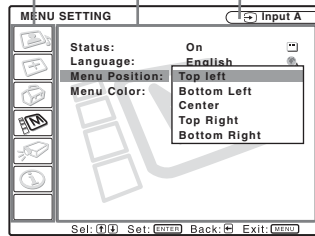



Sub menu

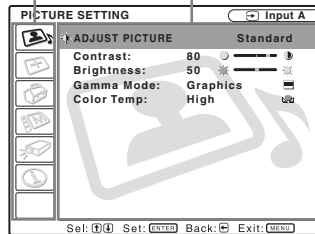

Menu Setting items



4 Make the setting or adjustment of an item.



• When changing the adjustment level:

To increase the number, press the  or  key.

To decrease the number, press the  or  key.

Press the ENTER key to restore the previous screen.

• When changing the setting:

Press the  or  key to change the setting.

Press the ENTER or  key to restore the previous screen.

To clear the menu

Press the MENU key.

The menu disappears automatically if a key is not pressed for one minute.

To reset items that have been adjusted

Select the item that you want to reset, and then press the RESET key on the Remote Commander.

“Complete!” appears on the screen and **the setting of the item that you have selected is factory preset values.**

Items that can be reset are:

- “Contrast,” “Brightness,” “Color,” “Hue” and “Sharpness” on the “Adjust Picture...” menu.
- “Dot Phase,” “H Size,” and “Shift” on the “Adjust Signal...” menu

Storage of the settings

The settings are automatically stored in the projector memory when the ENTER key is pressed.

If no signal is input

If there is no input signal, “Cannot adjust this item.” appears on the screen.

Unadjustable items

Items that cannot be adjusted, depending on the input signal, are not displayed on the menu.

For details, see page 35.

The PICTURE SETTING Menu

The PICTURE SETTING menu is used for adjusting the picture or volume. Items that can be adjusted or set depend on the kind of input signals. For details, see “Input signals and adjustable/setting items” on page 35.

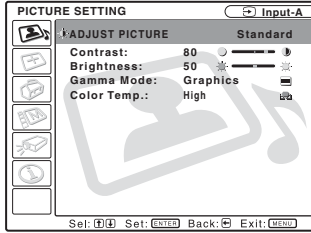
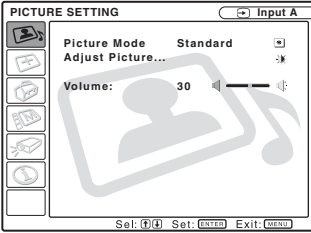

Setting items	Functions	Initial setting
Picture Mode	Selects the picture mode. <ul style="list-style-type: none"> • Dynamic: Emphasizes the contrast to produce a “dynamic” picture. • Standard: Normally select this setting. If the picture has roughness with the “Dynamic” setting, this setting reduces the roughness. 	Standard
Adjust Picture...	The unit can store the setting values of the following sub menu items for each “Dynamic” or “Standard” picture mode separately.	
Contrast	Adjusts the picture contrast.	80
Brightness	Adjusts the picture brightness.	50
Color	Adjusts color intensity.	50
Hue	Adjusts color tones. The higher the setting, the more greenish the picture becomes. The lower the setting, the more purplish.	50
Sharpness	Selects the picture sharpness from among “High,” “Middle,” and “Low.” The “High” setting makes the picture sharp; the “Low” setting makes it soft.	High
Gamma Mode	Selects a gamma correction curve. <ul style="list-style-type: none"> • Graphics: Improves the reproduction of halftones. Photos can be reproduced in natural tones. • Text: Contrasts black and white. Suitable for images that contain lots of text. 	Graphics
Color Temp.	Adjusts the color temperature. <ul style="list-style-type: none"> • High: Makes white colors bluish. • Low: Makes white colors reddish. 	High Low (Video/S-Video)
Volume	Adjusts the volume.	30

The INPUT SETTING Menu

The INPUT SETTING menu is used to adjust the input signal.

Items that can be adjusted or set depend on the kind of input signals. For details, see “Input signals and adjustable/setting items” on page 35.

When the video signal is input

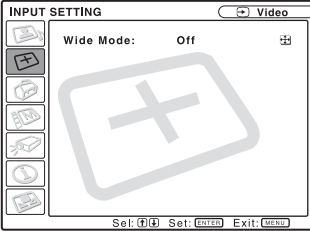

Setting items	Functions	Initial setting
Wide Mode	Sets the aspect ratio of the picture. <ul style="list-style-type: none"> • Off: When a picture with a ratio of 4:3 is input. • On: When a picture with a ratio of 16:9 (squeezed) is input from a DVD player. 	Off

When the signal is input from a computer

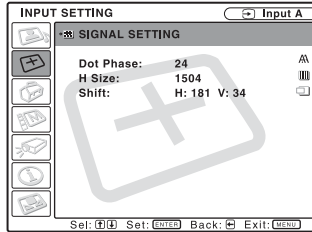
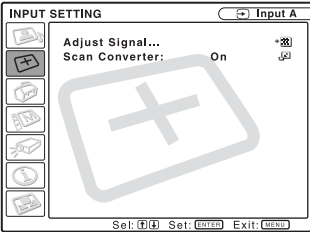

Setting items	Functions	Initial setting
Adjust Signal...		
Dot Phase	Adjusts the dot phase of the LCD panel and the signal output from a computer. Adjust the picture further for finer picture after the picture is adjusted by pressing the APA key.	
H Size	Adjusts the horizontal size of a picture output from a computer. Adjust the setting according to the dots of the input signal. For details, see page 46.	Set according to the input signal

Setting items	Functions	Initial setting
Shift	Adjusts the position of the picture. H adjusts the horizontal position of the picture. V adjusts the vertical position of the picture. As the setting for H increases, the picture moves to the right, and as the setting decreases, the picture moves to the left. As the setting for V increases, the picture moves up, and as the setting decreases, the picture moves down. Use the ← or the → key to adjust the horizontal position and the ↑ and ↓ key for the vertical position.	Set according to the input signal
Scan Converter	Converts the signal to display the picture according to the screen size. When set to "Off," displays the picture while matching one pixel of input picture element to that of the LCD. The picture will be clear but the picture size will be smaller.	On

Note

Note that if the projector is used for profit or for public viewing, modifying the original picture by switching to the wide mode may constitute an infringement of the rights of authors or producers, which are legally protected.

About the Preset Memory No.

This projector has 45 types of preset data for input signals (the preset memory). When a preset signal is input, the projector automatically detects the signal type and recalls the data for the signal from the preset memory to adjust it to an optimum picture. The memory number and signal type of that signal are displayed on the INFORMATION menu (See page 34). You can also adjust the preset data through the INPUT SETTING menu.

This projector has 20 types of user memories for Input-A into which you can save the setting of the adjusted data for an unpreset input signal.

When an unpreset signal is input for the first time, a memory number is displayed as 0.

When you adjust the data of the signal using the INPUT SETTING menu, it will be registered in the projector. If more than 20 user memory items are registered, the newest memory always overwrites the oldest one.

See the chart on page 46 to find if the signal is registered in the preset memory.

Since the data for the following signals is recalled from the preset memory, you can

use these preset data items by adjusting "H Size." Make finer adjustments by adjusting "Shift."

Signal	Memory No.	SIZE
Super Mac-2	23	1312
SGI-1	23	1320
Macintosh 19"	25	1328
Macintosh 21"	27	1456
Sony News	36	1708
PC-9821 1280 × 1024	36	1600
WS Sunmicro	37	1664

Note

When the aspect ratio of input signal is other than 4:3, a part of the screen is displayed in black.

The SET SETTING Menu

The SET SETTING menu is used for changing the settings of the projector.

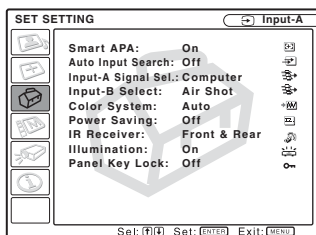

Setting items	Functions	Initial setting
Smart APA	<p>The APA (Auto Pixel Alignment) automatically adjusts “Dot Phase,” “H Size” and “Shift” on the INPUT SETTING menu for the input signal from a computer.</p> <ul style="list-style-type: none"> • On: When a signal is input from a computer, the APA functions automatically so that the picture can be seen clearly. Once the specified input signal has been adjusted by the “Smart APA,” it will not be readjusted even when the cable is disconnected and connected again or the input channel is changed. You can adjust the picture by pressing the APA key on the Remote Commander even if “Smart APA” set to “On.” • Off: The APA functions when you press the APA key on the Remote Commander. 	On
Auto Input Search	When set to “On,” the projector detects input signals in the following order: Input-A/Input-B (VPL-CX76 only) /Video/S-Video. It indicates the input channel when the power is turned on (only when “startup” in Memory Stick Home is set to “Off” (VPL-CX76 only)) or the INPUT key is pressed.	Off
Input-A Signal Sel.	Selects the “Computer,” “Component,” or “Video GBR” signal input via the INPUT A connector.	Computer
Input-B Select (VPL-CX76 only)	Select “Air Shot” or “Memory Stick” as the input source that you want to project via Input-B.	Air Shot
Color System	<p>Selects the color system of the input signal. If you select “Auto,” the projector detects the color system of the input signal automatically. If the picture is distorted or colorless, select the color system according to the input signal.</p> <p>When the color system of the input signal is PAL60, select “PAL.” If “Auto” is selected, the color system cannot be detected.</p>	Auto

Setting items	Functions	Initial setting
Power Saving	When set to “On,” the projector goes into power saving mode if no signal is input for 10 minutes. Although the lamp goes out, the cooling fan keeps running. The power saving mode is canceled when a signal is input or any key is pressed. In power saving mode, no keys function for the first 45 seconds after the lamp goes out.	Off
IR Receiver	Selects the remote control detectors (IR Receiver) on the front and rear of the projector. <ul style="list-style-type: none"> • Front & Rear: Activates both the front and rear detectors. • Front: Activates the front detector only. • Rear: Activates the rear detector only. 	Front & Rear
Illumination	Selects whether the SONY logo on the top panel of the projector lights when the projector is on. Normally, this setting is “On.”	On
Panel Key Lock	Locks all the control panel keys on the rear and side panels of the projector so that the projector can be operated only with the Remote Commander. To lock the control panel keys, set to “On.” When it is set to “On,” keeping the I/⏻ key on the control panel pressed for 10 seconds turns the projector on when it is in standby mode, and turns the projector to standby mode when the power is on. If you press and hold the MENU key for about 10 seconds when the power is on, the lock will be released and “Panel Key Lock” is automatically set to “Off.”	Off

Notes

- Press the APA key when the full image is displayed on the screen. If the projected image includes a black portion around it, the APA function will not work properly and some parts of the image may not be displayed on the screen.
- You can cancel the adjustment by pressing the APA key again while “Adjusting” appears on the screen.
- The picture may not be adjusted properly depending on the type of input signal.
- Adjust the “Dot Phase,” “H Size,” and “Shift” items on the INPUT SETTING menu when you adjust the picture manually.

The MENU SETTING Menu

The MENU SETTING menu is used for changing the menu displays.

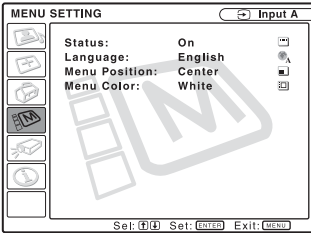



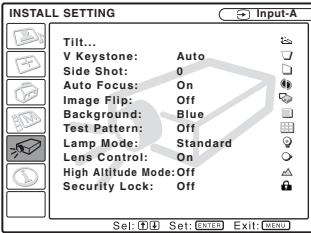

Setting items	Functions	Initial setting
Status (on-screen display)	Sets up the on-screen display. When set to “Off,” turns off the on-screen displays except for the menus, a message when the power is turned off, and warning messages.	On
Language	Selects the language used in the menu and on-screen displays. The languages available are: English, Nederlands, Français, Italiano, Deutsch, Español, Português, Русский, Svenska, Norsk, 日本語, 中文(简体字), 中文(繁體字), 한국어 and ภาษาไทย.	English
Menu Position	Selects the display position of the menu from “Top Left,” “Bottom Left,” “Center,” “Top Right,” and “Bottom Right.”	Center
Menu Color	Selects the tone of the menu display from “Black” or “White.”	White

The INSTALL SETTING Menu

The INSTALL SETTING menu is used for changing the settings of the projector.



Setting items	Functions	Initial setting
Tilt...	Adjusts the position (height) of the projected picture.	
V Keystone	<p>Corrects the trapezoidal distortion caused by the projection angle. Select “Auto” for automatic correction, or “Manual” for manual correction using the ←/↑/→/↓ keys on the Remote Commander.</p> <p>When the bottom of the trapezoid is longer than the top  : Sets a lower value.</p> <p>When the top of the trapezoid is longer than the bottom  : Sets a higher value.</p>	Auto
Side Shot	<p>Corrects the horizontal trapezoidal distortion of the picture using the ←/↑/→/↓ keys on the Remote Commander.</p> <p>When the right side is longer than the left side  Set to a higher value (+ direction).</p> <p>When the left side is longer than the right side  Set to a lower value (– direction).</p> <p>Set the adjustment level to “0” if you want to adjust the picture more widely using “V Keystone” only.</p>	0
Auto Focus	When set to “Off,” the focus adjustment does not work automatically when the projector is turned on.	On
Image Flip	<p>Flips the image on the screen horizontally and/or vertically.</p> <ul style="list-style-type: none"> • Off: The image does not flip. • HV: Flips the image horizontally and vertically. • H: Flips the image horizontally. • V: Flips the image vertically. 	Off
Background	Selects the background color of the screen when no signal is input to the projector. Select “Black” or “Blue.” Normally, set to “Blue.”	Blue
Test Pattern	When set to “On,” a test pattern is displayed on the screen during “Lens Zoom” adjustment, “Lens Focus,” “Side Shot,” or “V Keystone.”	Off
Lamp Mode	<p>Sets the lamp brightness used during the projection.</p> <ul style="list-style-type: none"> • High: Illuminates the projected image brightly. • Standard: Reduces fan noise and power consumption. The brightness of the projected image will be lower compared with the “High” setting. 	Standard



Setting items	Functions	Initial setting
Lens Control	When set to “Off,” the LENS (FOCUS, ZOOM) key on the Remote Commander, and the FOCUS and ZOOM keys on the projector do not function.	On
High Altitude Mode	Set to “On” when the projector is used at an altitude of 1,500 m or higher.	Off
Security Lock	Turns on the projector’s security lock function. When set to “On,” turns on the security lock function, which locks the projector once a password has been set. <i>For details, see “Security Lock” on page 20.</i>	Off

Notes

- The auto V Keystone adjustment may not correct the trapezoidal distortion perfectly, depending on the room temperature or the screen angle.
- Even when projecting using “Side Shot”, the four sides of a picture may sometimes not be parallel to the respective sides of a screen frame.

The INFORMATION Menu

The INFORMATION menu displays the model name, serial number, the horizontal and vertical frequencies of the input signal and the cumulated hours of usage of the lamp.

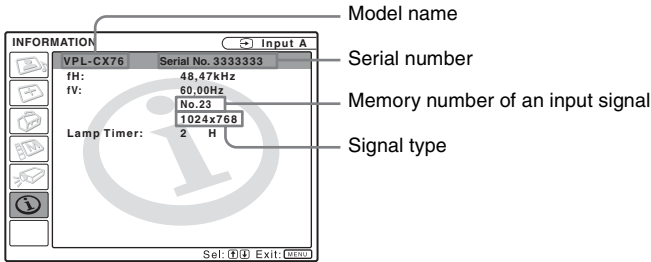

Setting items	Functions
fH	Displays the horizontal frequency of the input signal. The displayed value is approximate.
fV	Displays the vertical frequency of the input signal. The displayed value is approximate.
Lamp Timer	Indicates how long the lamp has been turned on.

Note

These are only displayed on the screen. You cannot alter the display, and these is no setting to be altered.

Input signals and adjustable/setting items

Adjust Picture... menu

Item	Input signal					
	Video or S-Video (Y/C)	Component	Video GBR	Computer	B&W	Air Shot or "Memory Stick"*2
Picture Mode	●	●	●	●	●	●
Adjust Picture...						
Contrast	●	●	●	●	●	●
Brightness	●	●	●	●	●	●
Color	●	●	●	–	–	–
Hue	● (NTSC 3.58/ 4.43 only)	●	●	–	–	–
Sharpness	●	●	●	–	●	–
Gamma Mode	–	–	●*1	●	–	●
Color Temp.	●	●	●	●	●	●
Volume	●	●	●	●	●	●

● : Adjustable/can be set

– : Not adjustable/cannot be set

*1: Preset memory No. 3, 4 only

*2: VPL-CX76 only

INPUT SETTING menu

Item	Input signal					
	Video or S-Video (Y/C)	Component	Video GBR	Computer	B&W	Air Shot or "Memory Stick"*3
Adjust Signal...						
Dot Phase	–	–	–	●	–	–
H Size	–	●*1	●*1	●	–	–
Shift	–	●*1	●*1	●	–	–
Scan Converter	–	–	–	● (lower than SVGA)	–	–
Wide Mode	●	●*2	●*2	–	●	–

● : Adjustable/can be set

– : Not adjustable/cannot be set

*1: Expect preset memory No. 3, 4

*2: Expect preset memory No. 5, 45, 47, 48, 50

*3: VPL-CX76 only

Replacing the Lamp

The lamp used as a light source is consumable product. Thus replace the lamp with a new one in the following cases.

- When the lamp has burnt out or dims
- “Please replace the Lamp.” appears on the screen
- The LAMP/COVER indicator lights up

The lamp life varies depending on conditions of use.

Use an LMP-C161 Projector Lamp as the replacement lamp.

Use of any other lamps than the LMP-C161 may cause damage to the projector.

Caution

The lamp remains hot after the projector is turned off with the I/⏻ key. **If you touch the lamp, you may burn your finger. When you replace the lamp, wait for at least an hour for the lamp to cool.**

Notes

- **If the lamp breaks, consult with qualified for personal.**
- Pull out the lamp by holding the handle. If you touch the lamp, you may be burned or injured.
- When removing the lamp, make sure it remains horizontal, then pull straight up. Do not tilt the lamp. If you pull out the lamp while it is tilted and if the lamp breaks, the pieces may scatter, causing injury.

- 1 Turn off the projector, and disconnect the AC power cord from the AC outlet.

Note

When replacing the lamp after using the projector, wait for at least an hour for the lamp to cool.

- 2 Place a protective sheet (cloth) beneath the projector. Turn the projector over so you can see its underside.

Note

Be sure that the projector is stable after turning it over.

- 3 Open the lamp cover by loosening the screw with a Phillips screwdriver.

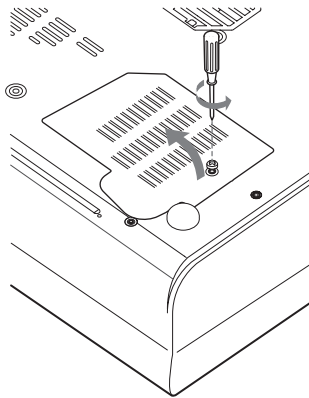

Note

For safety reasons, do not loosen any other screws.

- 4 Loosen the two screws on the lamp unit with the Phillips screwdriver (1). Fold out the handle (2), then pull out the lamp unit by the handle (3).

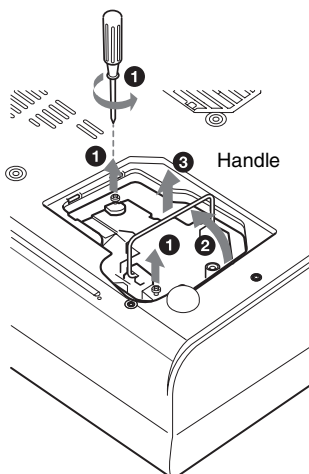

- 5** Insert the new lamp all the way in until it is securely in place (1). Tighten the two screws (2). Fold down the handle to replace it (3).

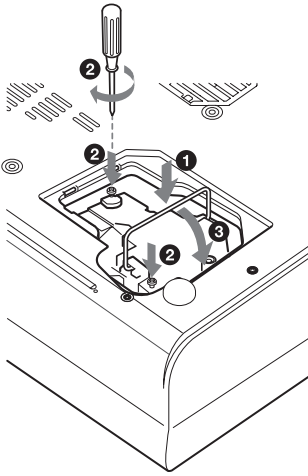

Caution

Do not put your hands into the lamp replacement slot, and do not allow any liquid or other objects into the slot **to avoid electrical shock or fire.**

Disposal of the used lamp

For the customers in the USA

This product contains mercury. Disposal of this product may be regulated if sold in the United States. For disposal or recycling information, please contact your local authorities or the Electronics Industries Alliance (<http://www.eiae.org>).

Notes

- Be careful not to touch the glass surface of the lamp.
- The power will not turn on if the lamp is not secured properly.

- 6** Close the lamp cover and tighten the screw.

Note

Be sure to attach the lamp cover securely as it was. If not, the projector cannot be turned on.

- 7** Turn the projector back over.
- 8** Connect the power cord.
The ON/STANDBY indicator around the I/⏻ key lights in red.
- 9** Press the following keys on the Remote Commander in the following order for less than five seconds each: RESET, ←, →, ENTER.

Cleaning the Air Filter

The air filter should be cleaned every 500 hours. Remove dust from the outside of the ventilation holes with a vacuum cleaner. 500 hours are approximate. This value varies depending on the environment or how the projector is used.

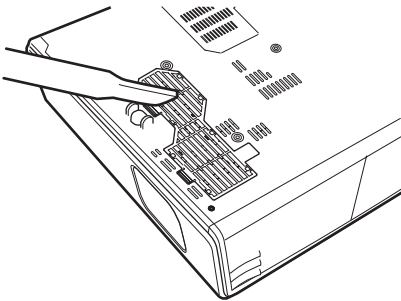

When it becomes difficult to remove the dust from the filter with a vacuum cleaner, remove the air filter and wash it.

- 1 Turn the power off and unplug the power cord.
- 2 Place a protective sheet (cloth) beneath the projector and turn the projector over.
- 3 Remove the air filter cover.

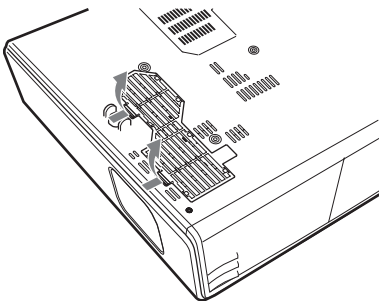

- 4 Remove the air filter.

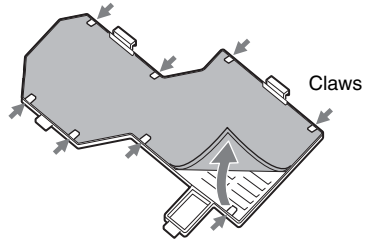

- 5 Wash the air filter with a mild detergent solution and dry it in a shaded place.
- 6 Attach the air filter so that it fits into the each claws (8 positions) on the air filter covers and replace the cover.

Notes

- If you neglect to clean the air filter, dust may accumulate, clogging it. As a result, the temperature may rise inside the unit, leading to a possible malfunction or fire.
- If the dust cannot be removed from the air filter, replace the air filter with the supplied new one.
- Be sure to attach the air filter cover firmly; the power can not be turned on if it is not closed securely.
- The air filter has a face and a reverse side. Place the air filter so that it fits in a notch on the air filter cover.
- To erase a message, press any key on the control panel of the projector or on the remote commander.

Troubleshooting

If the projector appears to be operating erratically, try to diagnose and correct the problem using the following instructions. If the problem persists, consult with qualified Sony personnel.

Power

Symptom	Cause and Remedy
The power is not turned on.	<ul style="list-style-type: none"> • The power has been turned off and on with the I/⏻ key at a short interval. → Wait for about 60 seconds before turning on the power (see page 18). • The lamp cover is not secured. → Close the lamp cover securely (see page 37). • The air filter cover is detached. → Attach the air filter cover securely (see page 38).
Both the LAMP/COVER and TEMP/FAN indicators light up.	<p>The electrical system has broken down. → Consult with qualified Sony personnel.</p>
The powered tilt adjuster and the lens protector do not close.	<p>The AC power cord was unplugged with the power of the projector turned on. → Connect the power cord to the AC outlet again, turn on the power of the projector, then turn it off.</p>
The lens protector cannot open.	<p>The electrical system has broken down. → Consult with qualified Sony personnel. If it is necessary to use the projector in case of emergency, slide the lens protector open by hand, and then press the I/⏻ key. You can now use the projector.</p>

Picture

Symptom	Cause and Remedy
No picture.	<ul style="list-style-type: none"> • A cable is disconnected or the connections are wrong. → Check that the proper connections have been made (see page 13). • The connections are wrong. → This projector is compatible with DDC2B (Digital Data Channel 2B). If your computer is compatible with DDC, turn the projector on according to the following procedures. <ol style="list-style-type: none"> 1 Connect the projector to the computer. 2 Turn the projector on. 3 Start the computer. • Input selection is incorrect. → Select the input source correctly using the INPUT key (see page 16). • The picture is muted. → Press the PIC MUTING key to release the picture muting (see page 9). • The B key is activated (VPL-CX76 only). → Press the B key on the Presentation Tool to deactivate the key (see page 11).

Symptom	Cause and Remedy
The picture is noisy.	Noise may appear on the background depending on the combination of the number of dots input from the computer and the numbers of pixels on the LCD panel. → Change the desktop pattern on the connected computer.
The picture from the INPUT A connector is colored strangely.	The setting of “Input-A Signal Sel.” on the SET SETTING menu is incorrect. → Select “Computer,” “Video GBR” or “Component” correctly according to the input signal (see page 29).
“Please check Input-A Signal Sel.” appears in spite of inputting the correct signal from INPUT A.	The setting of “Input-A Signal Sel.” on the SET SETTING menu is incorrect. → Select “Computer,” “Video GBR” or “Component” correctly according to the input signal (see page 29).
On-screen display does not appear.	“Status” on the MENU SETTING menu has been set to “Off.” → Set “Status” on the MENU SETTING menu to “On” (see page 32).
Color balance is incorrect.	<ul style="list-style-type: none"> • The picture has not been adjusted properly. → Adjust the picture (see page 26). • The projector is set to the wrong color system. → Set “Color System” on the SET SETTING menu to match the color system being input (see page 29).
The picture is too dark.	<ul style="list-style-type: none"> • Contrast or brightness has not been adjusted properly. → Adjust the contrast or brightness on the “Adjust Picture...” menu properly (see page 26). • The lamp has burnt out or is dim. → Replace the lamp with a new one (see page 36).
The picture is not clear.	<ul style="list-style-type: none"> • The picture is out of focus. → Adjust the focus (see page 17). • Condensation has accumulated on the lens. → Leave the projector for about two hours with the power on.
The image extends beyond the screen.	The APA key has been pressed even though there are black edges around the image. → Display the full image on the screen and press the APA key. → Adjust “Shift” on the INPUT SETTING menu properly (see page 28).
The picture flickers.	“Dot Phase” on the INPUT SETTING menu has not been adjusted properly. → Adjust “Dot Phase” on the INPUT SETTING menu properly (see page 27).

Sound

Symptom	Cause and Remedy
No sound.	<ul style="list-style-type: none"> • A cable is disconnected or the connections are wrong. → Check that the proper connections have been made (see page 13). • The audio connecting cable used is incorrect. → Use a no-resistance stereo audio cable (see page 13). • The sound is muted. → Press the AUDIO MUTING key to release audio muting (see page 9). • The sound is not adjusted properly. → Adjust the sound with the VOLUME +/- key on the Remote Commander or adjust “Volume” on the PICTURE SETTING menu (see page 26).

Remote Commander/Presentation tool

Symptom	Cause and Remedy
The Remote Commander does not work.	<ul style="list-style-type: none"> • The Remote Commander batteries are dead. → Replace them with new batteries (see page 10). • The COMMAND ON/OFF switch is set to OFF. → Set it to ON. • The PJ NETWORK selector switch is set to NETWORK. → Set it to PJ.
The computer cannot be controlled with the Remote Commander.	<ul style="list-style-type: none"> • The USB cable is not connected. → Connect the projector to the computer using the USB cable. • You are operating the Air Shot (VPL-CX76 only). → When using the Air Shot, the computer cannot be controlled with the Remote Commander. Use the presentation tool.
The computer cannot be controlled with the presentation tool (VPL-CX76 only).	<ul style="list-style-type: none"> • The USB cable is being used. • The Air Shot is not being used. → The presentation tool is designed to be used with the Air Shot. Use the Remote Commander to operate the device connected via the USB cable.

Others

Symptom	Cause and Remedy
The control panel keys do not function.	<p>The control panel keys are locked. → Unlock the control panel keys (see page 30).</p>

Indicators

Symptom	Cause and Remedy
The LAMP/COVER indicator flashes.	<ul style="list-style-type: none"> • The lamp cover or the air filter cover is detached. → Attach the cover securely (see pages 37 and 38). • The lens protector did not open due to a problem. → In case of emergency, slide the lens protector open by hand, and then press the I/⏻ key. If this problem occurs again, consult with qualified Sony personnel. • The electrical system may have broken down. → Consult with qualified Sony personnel.
The LAMP/COVER indicator lights up.	<ul style="list-style-type: none"> • The lamp has reached the end of its life. → Replace the lamp (see page 36). • The lamp has reached a high temperature. → Wait for 60 seconds to cool the lamp and then turn on the power again. • If the LAMP/COVER indicator still lights even after you have replaced the lamp, the electrical system may break down. → Consult with qualified Sony personnel.
The TEMP/FAN indicator flashes.	<p>The fan is broken. → Consult with qualified Sony personnel.</p>
The TEMP/FAN indicator lights up.	<ul style="list-style-type: none"> • The internal temperature is unusually high. → Check to see that nothing is blocking the ventilation holes. • The projector is being used at a high altitude. → Ensure that “High Altitude Mode” on the INSTALL SETTING menu is set to “On.”
Both the LAMP/COVER and TEMP/FAN indicators light up.	<p>The electrical system has broken down. → Consult with qualified Sony personnel.</p>

Messages List

Warning Messages

Use the list below to check the meaning of the messages displayed on the screen.

Message	Meaning and Remedy
High temp! Probably use in high altitude. Switch to high altitude mode on? Yes ↑ No ↓	<p>Internal temperature is too high.</p> <ul style="list-style-type: none"> → When using the projector at an altitude of 1,500 m or higher, set “High Altitude Mode” on the INSTALL SETTING menu to “On” (see page 33). → If this message appears on the screen when using the projector at normal altitudes, check to see if anything is blocking the ventilation holes (exhaust).
High temp.! Lamp off in 1 min.	<p>The internal temperature is too high.</p> <ul style="list-style-type: none"> → Turn off the power. → Check to see that nothing is blocking the ventilation holes.

Message	Meaning and Remedy
Frequency is out of range!	<ul style="list-style-type: none"> • This input signal cannot be projected as the frequency is out of the acceptable range of the projector. → Input a signal that is within the range of the frequency. • The resolution setting of the output signal of the computer is too high. → Set the output setting to XGA (see page 13).
Please check Input-A Signal Sel.	<p>You have input an RGB signal from the computer when “Input-A Signal Sel.” on the SET SETTING menu is set to “Component.”</p> <p>→ Set “Input-A Signal Sel.” correctly (see page 29).</p>
Please replace the Lamp.	<ul style="list-style-type: none"> • It is time to replace the lamp. → Replace the lamp. • When this message appears even after replacing the lamp, the task has not been completed. → Perform the operation of steps 8 and 9 on page 37. → To erase a message, press any key on the control panel of the projector or on the remote commander.
Please clean the filter.	<p>It is time to clean the filter.</p> <p>→ Clean the filter (see page 38).</p>

Caution Messages

Use the list below to check the meaning of the messages displayed on the screen.

Message	Meaning and Remedy
Not applicable!	<p>You have pressed the wrong key.</p> <p>→ Press the appropriate key.</p>
The panel keys are locked!	<p>“Panel Key Lock” on the INSTALL SETTING menu is set to “On.”</p> <p>→ All the keys on the control panel of the projector are locked. Operate the projector with the keys on the Remote Commander (see page 30).</p>

Specifications

Optical characteristics

Projection system	3 LCD panels, 1 lens, projection system
LCD panel	0.79-inch XGA panel, about 2,360,000 pixels (786,432 pixels × 3)
Lens	1.2 times zoom lens (powered) f 23.5 to 28.2 mm/F1.6 to 1.78
Lamp	165 W UHP
Projected picture size	40 to 300 inches (measured diagonally)
Light output	ANSI lumen ¹⁾ 2500 lm (VPL-CX76) ANSI lumen ¹⁾ 2000 lm (VPL-CX70) (When the Lamp Mode is set to “High.”)
Throwing distance (When placed on the floor.)	When an XGA signal is input 40-inch: 1.2 to 1.4 m (3.9 to 4.6 feet) 80-inch: 2.4 to 2.7 m (7.9 to 8.9 feet) 100-inch: 3.0 to 3.4 m (9.8 to 11.2 feet) 150-inch: 4.5 to 5.2 m (14.8 to 17.1 feet) 200-inch: 6.0 to 6.9 m (19.7 to 22.6 feet) 250-inch: 7.5 to 8.7 m (24.6 to 28.5 feet) 300-inch: 9.0 to 10.4 m (29.5 to 34.1 feet)

There may be a slight difference between the actual value and the design value shown above.

¹⁾ ANSI lumen is a measuring method described in American National Standard IT 7.228.

Electrical characteristics

Color system	NTSC ^{3.58} /PAL/SECAM/ NTSC ^{4.43} /PAL-M/PAL-N/ PAL60 system, switched automatically/manually (NTSC ^{4.43} is the color system used when playing back a video recorded in NTSC on a NTSC ^{4.43} system VCR.)
Resolution	750 horizontal TV lines (Video input) 1,024 × 768 dots (RGB input)

Acceptable computer signals¹⁾

fH: 19 to 92 kHz

fV: 48 to 92 Hz

(Maximum input signal resolution:

SXGA+ 1400 × 1050

fV: 60 Hz)

¹⁾ Set the resolution and the frequency of the signal of the connected computer within the range of acceptable preset signals of the projector.

Applicable video signals

15 k RGB 50/60 Hz, Progressive
component 50/60 Hz, DTV
(480/60i, 575/50i, 480/60p,
575/50p, 540/60p, 720/60p,
720/50p, 1080/60i, 1080/50i),
Composite video, Y/C video

Speaker Monaural speaker system, 40 × 20
mm (1 ⁵/₈ × ¹³/₁₆ inches)

Speaker output

1 W (max.)

Input/Output

Video input	VIDEO: phono type Composite video: 1 Vp-p ±2 dB sync negative (75 ohms terminated) S VIDEO: Y/C mini DIN 4-pin type Y (luminance): 1 Vp-p ±2 dB sync negative (75 ohms terminated) C (chrominance): burst 0.286 Vp-p ±2 dB (NTSC) (75 ohms terminated), burst 0.3 Vp-p ±2 dB (PAL) (75 ohms terminated)
INPUT A	HD D-sub15-pin (female) Analog RGB/component: R/R-Y: 0.7 Vp-p ±2 dB (75 ohms terminated) G: 0.7 Vp-p ±2 dB (75 ohms terminated) G with sync/Y: 1 Vp-p ±2 dB sync negative (75 ohms terminated) B/B-Y: 0.7 Vp-p ±2 dB (75 ohms terminated) SYNC/HD: Composite sync input: 1-5 Vp-p high impedance, positive/ negative Horizontal sync input: 1-5 Vp-p high impedance, positive/ negative VD: Vertical sync input: 1-5 Vp-p

high impedance, positive/negative

AUDIO Stereo minijack, 500 mVrms, input impedance 47 kilohms

USB Up (female) × 1

Wireless LAN card slot (VPL-CX76 only) × 1

“Memory Stick” slot (VPL-CX76 only) × 1

Safety regulations
 UL60950, cUL (CSA No. 60950), FCC Class B, IC Class B, DEMKO (EN60950), CE (LVD, EMC), C-Tick

VPL-CX76 only
 Presentation tool (1)
 Size AAA (R03) batteries (2)
 Wireless LAN card (1)
 USB wireless LAN module (IFU-WLM2) (1)

Design and specifications are subject to change without notice.

Laser (VPL-CX76 only)

Laser type Class 2
Wavelength 640 nm - 660 nm
Output 1 mW

General

Dimensions 298 × 69 × 243.5 mm (11 ³/₄ × 2 ³/₄ × 9 ⁵/₈ inches) (w/h/d) (without projecting parts)

Mass Approx. 2.9 kg (6 lb 8 oz)

Power requirements
 AC 100 to 240 V, 2.4 to 1.0 A, 50/60 Hz

Power consumption
 Max. 240 W
 in standby: 9 W (VPL-CX76), 4 W (VPL-CX70)

Heat dissipation
 819.0 BTU

Operating temperature
 0°C to 35°C (32°F to 95°F)

Operating humidity
 35% to 85% (no condensation)

Storage temperature
 -20°C to +60°C (-4°F to +140°F)

Storage humidity
 10% to 90%

Supplied accessories
 Remote Commander (1)
 Size AA (R6) batteries (2)
 HD D-sub 15 pin cable (2 m) (1) (1-791-992-xx)
 USB cable A type - B type (1) (1-790-081-xx)
 Carrying case (1)
 AC power cord (1)
 Air filter (for replacement) (1)
 CD-ROM (Application software and Operating instructions) (1)
 Quick Reference Manual (1)
 Safety Regulations (1)
 Security Label (1)

Optional accessories

Projector Lamp
 LMP-C161 (for replacement)

Signal Cable SMF-402 (HD D-sub 15-pin (male) ↔ 3 × phono type (male))

USB Wireless LAN Module
 IFU-WLM2

Some of the items may not be available in some areas. For details, please consult your nearest Sony dealer.

Pin assignment

INPUT A connector (HD D-sub 15-pin, female)

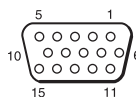

1	R/R-Y	9	N.C.
2	G/Y	10	GND
3	B/B-Y	11	GND
4	GND	12	DDC/SDA
5	GND	13	HD/C.Sync
6	GND (R)	14	VD
7	GND (G)	15	DDC/SCL
8	GND (B)		

Others

Preset signals

Memory No.	Preset signal		fH (kHz)	fV (Hz)	Sync	SIZE
1	Video 60 Hz	60 Hz	15.734	59.940		
2	Video 50 Hz	50 Hz	15.625	50.000		
3	480/60i	480/60i	15.734	59.940	S on G/Y or Composite Sync	
4	575/50i	575/50i	15.625	50.000	S on G/Y or Composite Sync	
5	1080/60i	1035/60i, 1080/60i	33.750	60.000	S on G/Y	
6	640 × 350	VGA mode 1	31.469	70.086	H-pos, V-neg	800
7		VGA VESA 85 Hz	37.861	85.080	H-pos, V-neg	832
8	640 × 400	PC-9801 Normal	24.823	56.416	H-neg, V-neg	848
9		VGA mode 2	31.469	70.086	H-neg, V-pos	800
10		VGA VESA 85 Hz	37.861	85.080	H-neg, V-pos	832
11	640 × 480	VGA mode 3	31.469	59.940	H-neg, V-neg	800
12		Macintosh 13"	35.000	66.667	H-neg, V-neg	864
13		VGA VESA 72 Hz	37.861	72.809	H-neg, V-neg	832
14		VGA VESA 75 Hz	37.500	75.000	H-neg V-neg	840
15		VGA VESA 85 Hz	43.269	85.008	H-neg V-neg	832
16	800 × 600	SVGA VESA 56 Hz	35.156	56.250	H-pos, V-pos	1024
17		SVGA VESA 60 Hz	37.879	60.317	H-pos, V-pos	1056
18		SVGA VESA 72 Hz	48.077	72.188	H-pos, V-pos	1040
19		SVGA VESA 75 Hz	46.875	75.000	H-pos, V-pos	1056
20		SVGA VESA 85 Hz	53.674	85.061	H-pos, V-pos	1048
21	832 × 624	Macintosh 16"	49.724	74.550	H-neg, V-neg	1152
22 ^{*1}	1024 × 768	XGA VESA 43 Hz	35.524	86.958	H-pos, V-pos	1264
23		XGA VESA 60 Hz	48.363	60.004	H-neg V-neg	1344
24		XGA VESA 70 Hz	56.476	69.955	H-neg V-neg	1328
25		XGA VESA 75 Hz	60.023	75.029	H-pos, V-pos	1312
26		XGA VESA 85 Hz	68.677	84.997	H-pos, V-pos	1376
27	1152 × 864	SXGA VESA 70 Hz	63.995	70.019	H-pos, V-pos	1472
28		SXGA VESA 75 Hz	67.500	75.000	H-pos, V-pos	1600
29		SXGA VESA 85 Hz	77.487	85.057	H-pos, V-pos	1568
30	1152 × 900	Sunmicro LO	61.795	65.960	H-neg, V-neg	1504
31		Sunmicro HI	71.713	76.047	Composite Sync	1472

Memory No.	Preset signal		fH (kHz)	fV (Hz)	Sync	SIZE
32	1280 × 960	SXGA VESA 60 Hz	60.000	60.000	H-pos, V-pos	1800
33		SXGA VESA 75 Hz	75.000	75.000	H-pos, V-pos	1728
34 ^{*1}	1280 × 1024	SXGA VESA 43 Hz	46.433	86.872	H-pos, V-pos	1696
35		SGI-5	53.316	50.062	S on G	1680
36		SXGA VESA 60 Hz	63.974	60.013	H-pos, V-pos	1696
37		SXGA VESA 75 Hz	79.976	75.025	H-pos, V-pos	1688
38 ^{*2}		SXGA VESA 85 Hz	91.146	85.024	H-pos, V-pos	1476
43		480/60p	480/60p (Progressive component)	31.470	60.000	S on G/Y
44	575/50p	575/50p (Progressive component)	31.250	50.000	S on G/Y	
45	1080/50i	1080/50i	28.130	50.000	S on G/Y	
47	720/60p	720/60p	45.000	60.000	S on G/Y	
48	720/50p	720/50p	37.500	50.000	S on G/Y	
50	540/60p	540/60p	33.750	60.000	S on G/Y	
52	1400 × 1050	SXGA+ 60 Hz	63.981	60.020	H-pos, V-pos	1688

Notes

- When a signal other than the preset signals shown above is input, the picture may not be displayed properly.
- Memory No. 22^{*1} and 34^{*1} show the interlace signal.
- For the Memory No. 38^{*2}, the smart APA function and the APA key of the remote commander do not activate. Make adjustments for the input signals using the Adjust Signal... on the INPUT SETTING menu.
- When an SXGA+ signal is input, the image may extend beyond the edges of the screen. In this case, input a signal with no black edges around the image, and disconnect and reconnect the cable or select the input signal by pressing the INPUT key.

Warning on power connection

Use the supplied power cord when you use the projector in your country/region. Otherwise, use a proper power cord meeting the following specifications.

	The United States, Canada	Continental Europe, Korea	UK	Australia	Japan
Plug type	YP-11	YP-21	SP-61	B8	YP-13
Female end	YC-13L	YC-13L	YC-13L	C7-2	YC-13L
Cord type	SPT-2	H03VVH2-F	H03VVH2-F	H03VVH2-F	VCTFK
Rated Voltage & Current	10A/125V	2.5A/250V	2.5A/250V	2.5A/250V	7A/125V
Safety approval	UL/CSA	VDE	BS	SAA	DENAN
Cord length (max.)	4.5 m	—	—	—	—

“Side Shot” and “V Keystone” Adjustments

With “Side Shot” (horizontal keystone adjustment) provided for the projector, you can project the picture from the side of the screen.

When projecting with “Side Shot” adjustment only, you can adjust the horizontal distortion of the screen to the maximum using “Side Shot.”

When projecting with both “Side Shot” and “V Keystone” (vertical keystone adjustment), you can adjust the vertical (◻ ◻) and horizontal (◻ ◻) distortion of the screen.

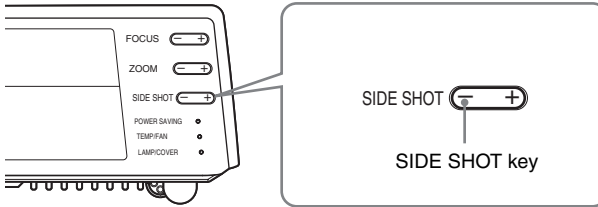

Adjustment Areas of “Side Shot” and “V Keystone”

The adjustable distortion area using “Side Shot” and “V Keystone” is described below.

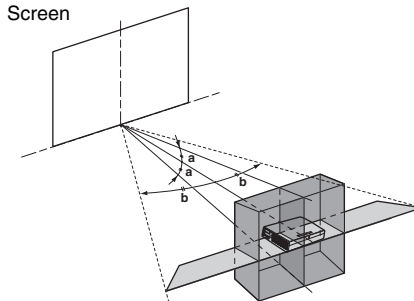

- a:** Tilting angle of the projector in the “V Keystone” adjustment area
- b:** “Side Shot” (H Keystone adjustment) area

Input signals		a	b
Video/60, Video/50, 480/60i, 575/50i, 480/60p, 575/50p	a=0	0	+/-20
	a≠0 or b≠0	+/-20	+/-11
	b=0	+/-30	0
1080/60i, 1080/50i, 540/60p	a=0	0	+/-16
	a≠0 or b≠0	+/-20	+/-11
	b=0	+/-30	0
720/60p, 720/50p	a=0	0	+/-16
	a≠0 or b≠0	+/-20	+/-7
	b=0	+/-30	0
PC, Air Shot (VPL-CX76 only), "Memory Stick" (VPL-CX76 only)	a=0	0	+/-14
	a≠0 or b≠0	+/-20	+/-7
	b=0	+/-30	0

Notes

- If "V Keystone" is set to "Auto," the "Side Shot" adjustment area may be narrow.
- "V Keystone" on the INSTALL SETTING menu is set to "Auto" at the factory, and the vertical distortion of the picture is automatically corrected. However, the distortion may not be perfectly corrected depending on the room temperature or the screen angle. In this case, set this item to "Manual," and correct the distortion using input values.

Dimensions

Front

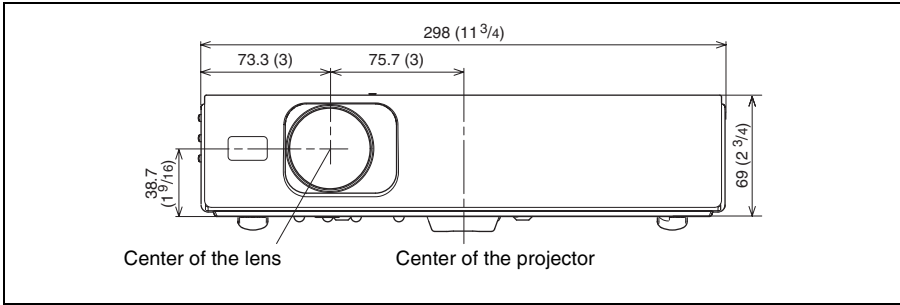

Left side

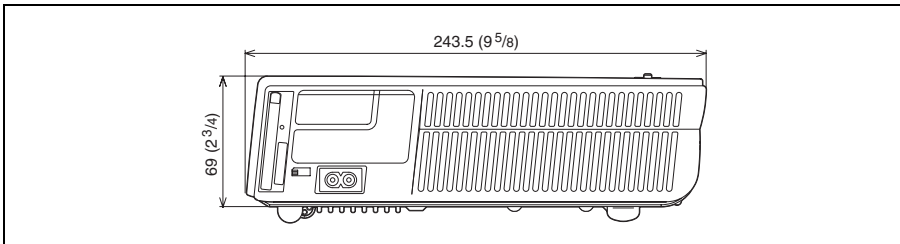

Top

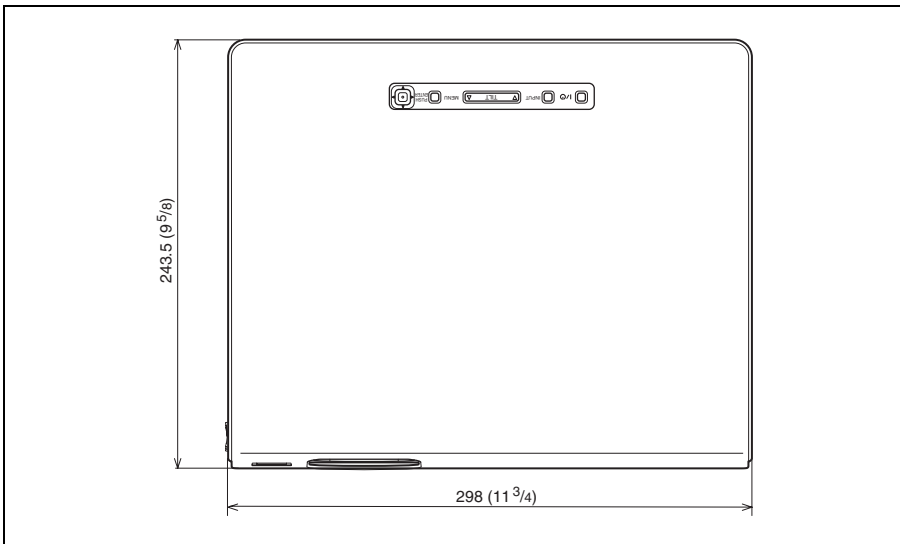

Unit: mm (inches)

Index

A

Adjusting	
memory of the settings	25
the picture	26
the picture size/shift	27, 28
Air filter	38
Auto Focus	32
Auto Input Search	29

B

Background	32
Batteries	10, 11
Brightness	26

C

Color	26
Color System	29
Color Temp.	26
Connecting a computer	13
Connecting a VCR	14
Contrast	26

D

Digital Zoom function	23
Dot Phase	27, 28

F

fH (Horizontal Frequency)	34
fV (Vertical Frequency)	34

G

Gamma Mode	26
------------	----

H

H Size	27, 28
High Altitude Mode	33
Hue	26

I

Illumination	30
Image Flip	32
Input-A Signal Sel.	29
Input-B Select	29
Installation	12

L

Lamp Mode	32, 33
Lamp replacement	36
Lamp Timer	34
Language	31
selecting the menu language	19
Lens Control	33
Lens protector	6
Location and function of controls	
connector panel	8
control panel	7
rear/right side/bottom	6
Remote Commander	9
top/front/left side	6

M

Menu	
clearing the menu display	25
INFORMATION Menu	34
INPUT SETTING menu	27
INSTALL SETTING menu	32
MENU SETTING menu	31
PICTURE SETTING menu	26
SET SETTING menu	29
using a menu	24
Menu Color	31
Menu Position	31
Message List	
caution	43
warning	42

O

Off & Go function	22
Optional accessories	45

P

Panel Key Lock	30
Picture Mode	26
Pin assignment	45
Power	
turn on	15
Power Saving	30
Powered tilt adjuster	16
Presentation tool	11
Projecting	15

R

Remote Commander	9
front remote control detector	6
location and function of controls	9
rear remote control detector	6
Reset	
resettable items	25
resetting an item	25

S

Scan Converter	28
Screen size	12, 44
Security Lock	33
Sharpness	26
Shift	28
Side Shot	32, 33
Smart APA	29
Specifications	44
Startup screen	16
Status	31
Supplied accessories	45

T

Test Pattern	32
Tilt... ..	32
Troubleshooting	39

U

USB connector	13
---------------------	----

V

V Keystone	32
Volume	26

W

Wide Mode	27
-----------------	----

